

**TBRE.CI**

TECHNICAL DATA		A-AXIS	C-AXIS
Maximum speed	°/sec	200	200
Continuous torque	Nm	560	1000
Intermittent torque	Nm	770	1560
Peak torque	Nm	1000	2000
Clamping torque	Nm	4500	10000
Hydraulic clamp rated pressure (max)	bar	120	120
Total mechanical Accuracy	arcsec	+/- 10"	+/- 10"
Angle rotation	°	+/-182°	+/-182°
Overall mass	Kg	630	

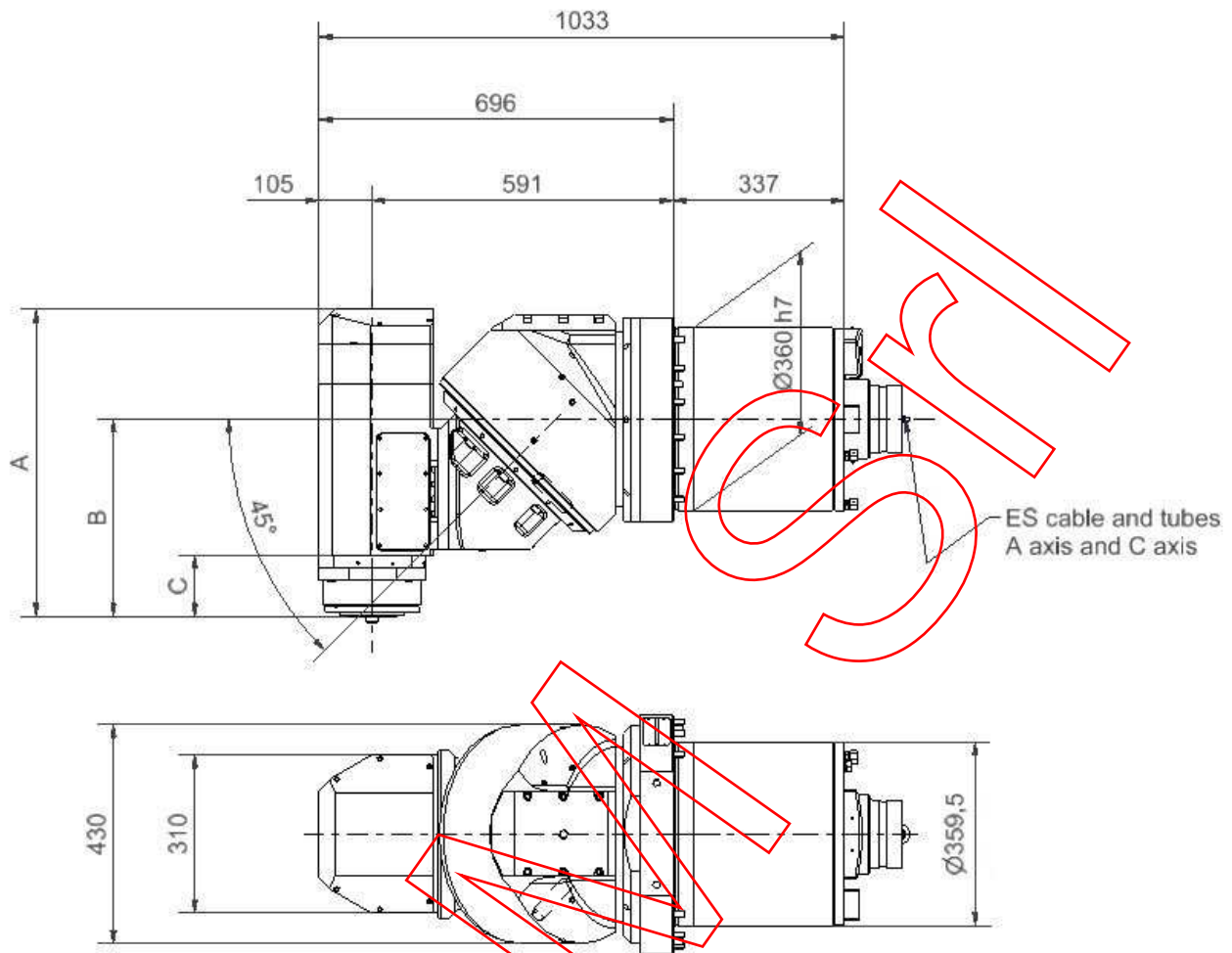

TECHNICAL DATA		SPINDLE **	
Tool type		HSK A63	HSK 100
Maximum spindle speed	Rpm		15000
Power S1 100% (S6 40%)	Kw		65Kw
Torque S1 100% (S6 40%)	Nm		124 Nm
Bearings lubrication type	Nm	Oil/Air	Oil/Air
Spindle manufacturer/model			HSD 6161 H1510

ELECTROSPINDLE TYPE **		
DIMENSION	HSK A63	HSK A100
A	525	560
B	350	350
C	100	135

\*\* Electric spindle type on request

We are available to supply special versions.