

**L15**

TECHNICAL DATA		A-AXIS	C-AXIS
Maximum speed	°/sec	200	200
Continuous torque	Nm	252	272
Intermittent torque	Nm	366	386
Peak torque	Nm	434	461
Clamping torque	Nm	4000	4000
Hydraulic clamp rated pressure (max)	bar	100	100
Accuracy	arcsec	+/- 10"	+/- 10"
Overall mass	Kg	450	

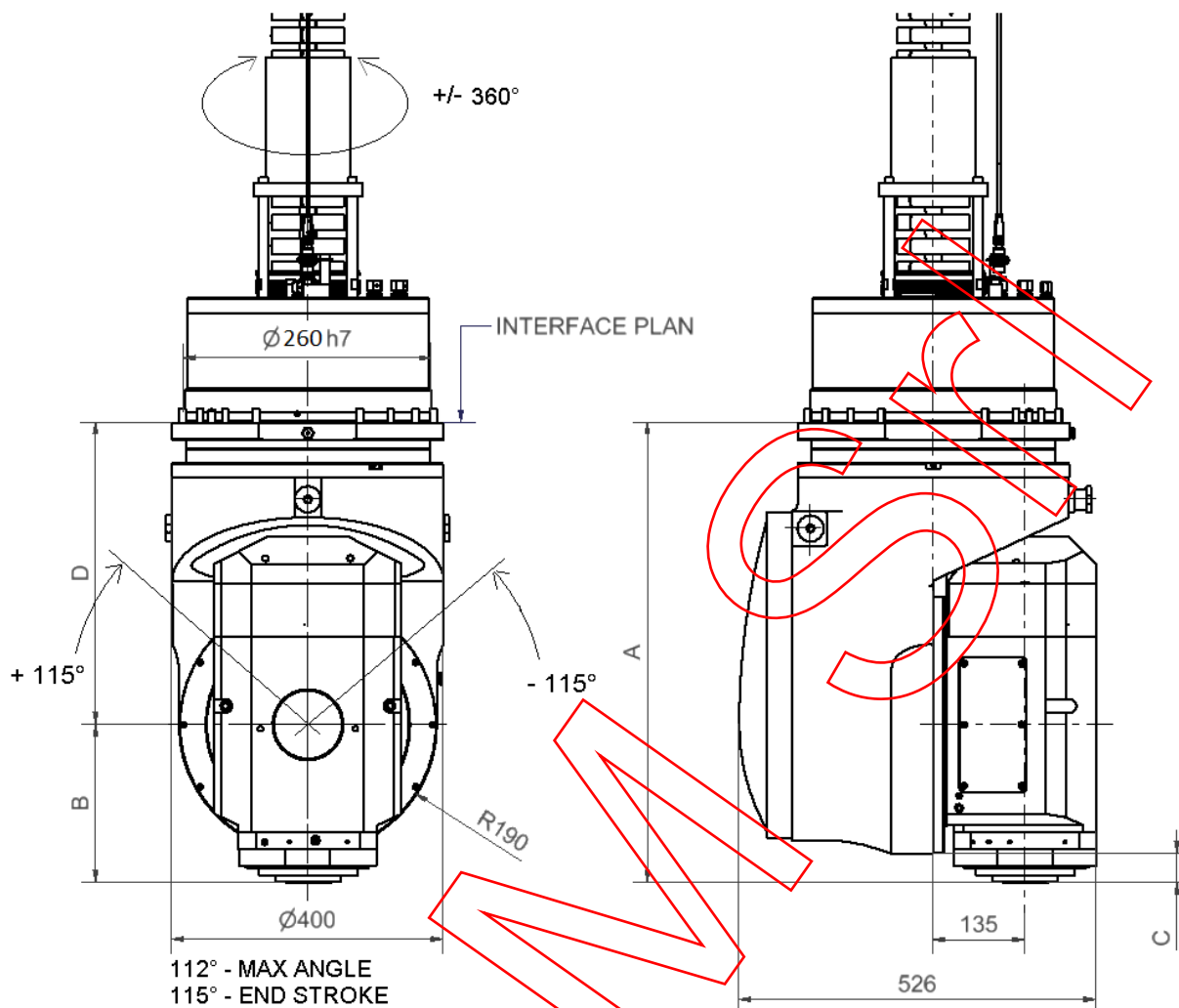

TECHNICAL DATA		SPINDLE	
Tool type		HSK A63	HSK A100
Maximum spindle speed	Rpm	24000	15000
Power S1 100% (S6 40%)	Kw	42 (55)	50 (67)
Torque S1 100% (S6 40%)	Nm	67 (87)	95 (124)
Bearings lubrication type	Nm	Oil/Air	Oil/Air
Spindle manufacturer/model		HSD ES510	HSD ES510

ELECTROSPINDLE TYPE				
DIMENSION	HSK A63 S version	HSK A63 L version	HSK A100 S version	HSK A100 L version
A	707	707 (opt.)	742	742 (opt.)
B	233	273 (opt.)	268	308 (opt.)
C	43	83 (opt.)	78	118 (opt.)
D	474	434 (opt.)	474	434 (opt.)

We are available to supply special versions.