

Head

TECHNICAL DATA		A-AXIS	C-AXIS
Maximum speed	°/sec	200	200
Continuous torque	Nm	252	406
Intermittent torque	Nm	366	578
Peak torque	Nm	500	698
Clamping torque	Nm	4000	4000
Hydraulic clamp rated pressure (max)	bar	100	100
Accuracy	arcsec	+/- 10"	+/- 10"
Overall mass	Kg	500	

Spindle

TECHNICAL DATA		SPINDLE	
Tool type		HSK A63	HSK A100
Maximum spindle speed	Rpm	24000	15000
Power S1 100% (S6 40%)	Kw	42 (55)	50 (67)
Torque S1 100% (S6 40%)	Nm	67 (87)	95 (124)
Bearings lubrication type	Nm	Oil/Air	Oil/Air
Spindle manufacturer/model		HSD ES510	HSD ES510

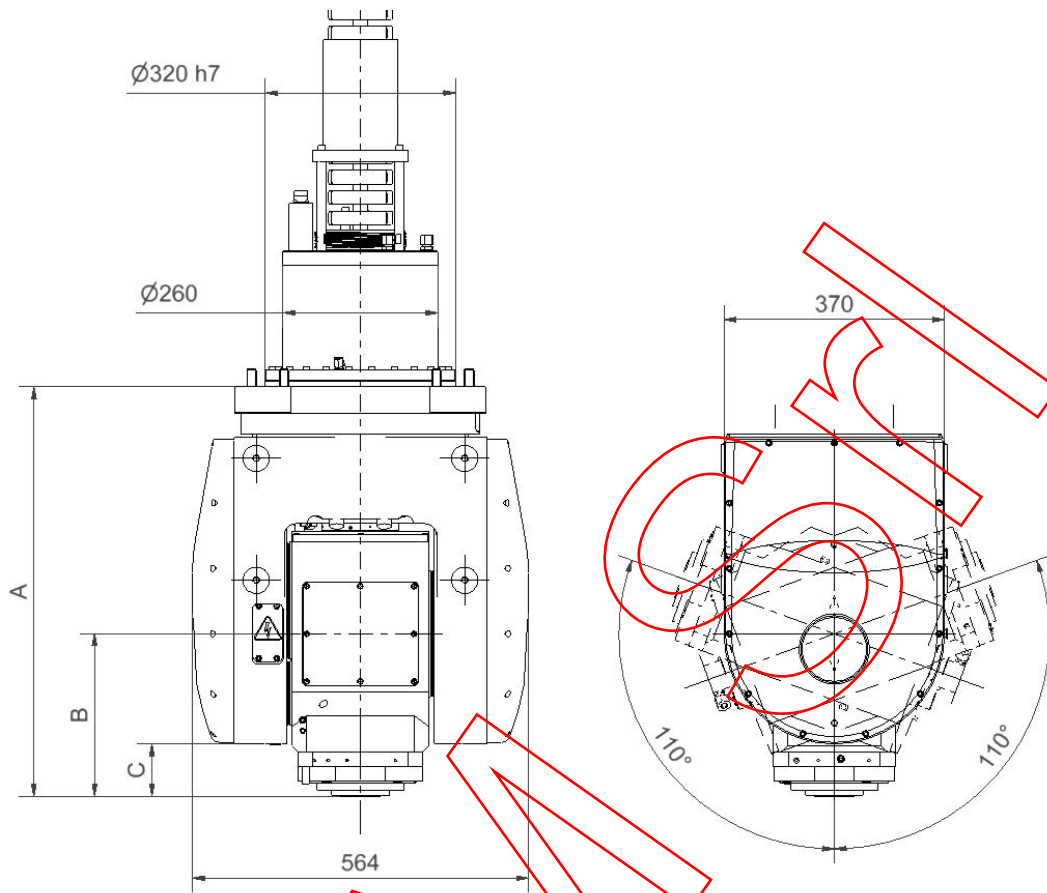

ELECTROSPINDLE TYPE		
DIMENSION	HSK A63	HSK A100
A	688	723
B	273	308
C	88	123

We are available to supply special versions