

Head

TECHNICAL DATA		A-AXIS	C-AXIS
Maximum speed	°/sec	200	200
Continuous torque	Nm	543	533
Intermittent torque	Nm	789	761
Peak torque	Nm	1030	935
Clamping torque	Nm	5000	5000
Hydraulic clamp rated pressure (max)	bar	100 (120)	60 (80)
Accuracy encoders	arcsec	+/- 10"	+/- 10"
Overall mass	Kg	600	

Spindle

TECHNICAL DATA		SPINDLE	
Tool type		HSK A63	HSK A100
Maximum spindle speed	Rpm	24000	15000
Power S1 100% (S6 40%)	Kw	42 (55)	50 (67)
Torque S1 100% (S6 40%)	Nm	67 (87)	95 (124)
Bearings lubrication type	Nm	Oil/Air	Oil/Air
Spindle manufacturer/model		HSD ES510	HSD ES510

We are available to supply special versions.

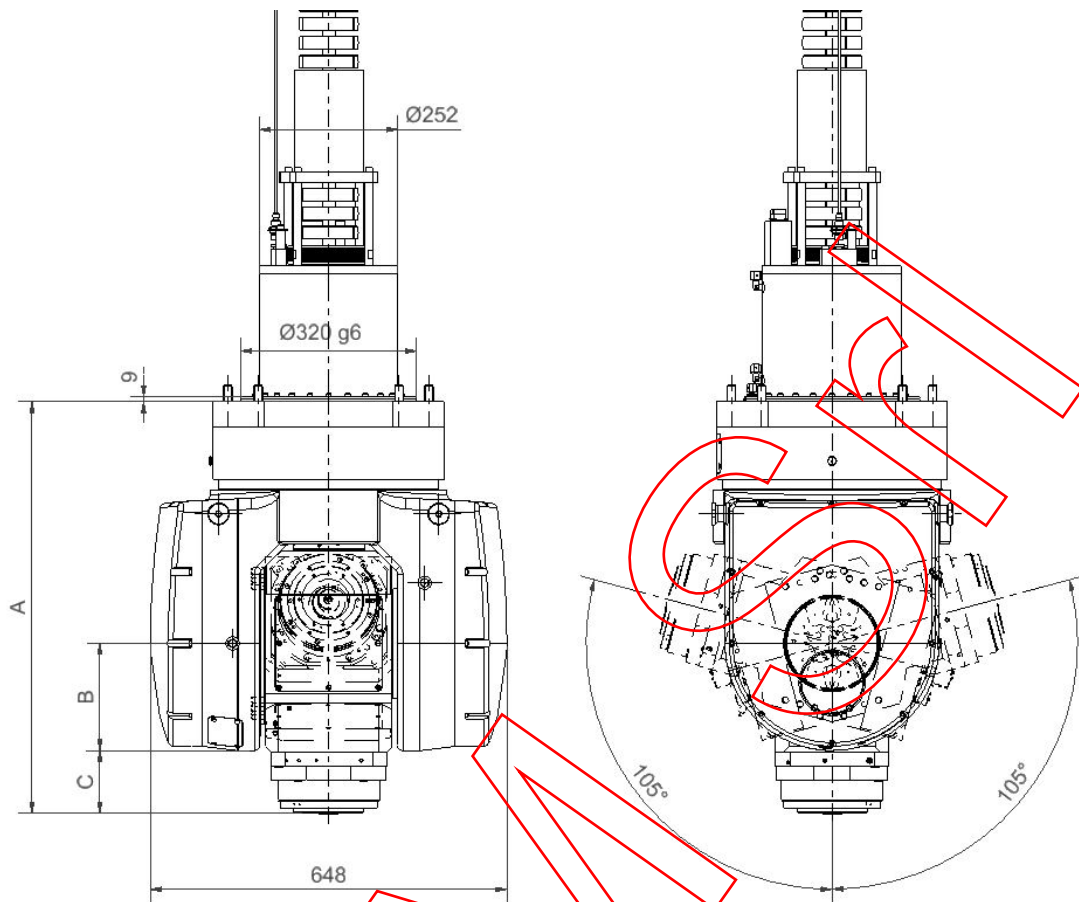

ELECTROSPINDLE TYPE		
DIMENSION	HSK A63	HSK A100
A	712	747
B	273	308
C	78	113